

INSTRUCTION MANUAL



TYPE **1001-A**

STANDARD-SIGNAL GENERATOR

1001-A

GENERAL RADIO COMPANY

INSTRUCTION MANUAL

TYPE **1001-A**

STANDARD-SIGNAL GENERATOR

Form 1001-0100-0

ID B100

September, 1967

GENERAL RADIO COMPANY
WEST CONCORD, MASSACHUSETTS, USA



SPECIFICATIONS

CARRIER FREQUENCY

Range: 5 kc/s to 50 Mc/s in 8 ranges of 5 to 15 kc/s, 15 to 50 kc/s, 50 to 150 kc/s, 150 to 500 kc/s, 0.5 to 1.5 Mc/s, 1.5 to 5 Mc/s, 5 to 15 Mc/s, and 15 to 50 Mc/s. Logarithmic scale up to 15 Mc/s, departs slightly from logarithmic at higher frequencies. Vernier-dial frequency increment is 0.1% per dial division up to 15 Mc/s

Accuracy: $\pm 1\%$ of reading.

Stability: Warmup drift is of the order of 0.25%. Half the maximum drift is reached in approximately 1½ hours.

Sweep: Maximum range with TYPE 1750-A Sweep Drive is 14%.

Distortion and Noise Level:

Envelope Distortion: Less than 8% at 80% amplitude modulation.

Carrier Noise Level: Corresponds to about 0.1% modulation.

Carrier Distortion: Of the order of 7% on all except 5 to 15 kc/s range, where it may increase to approximately 15%.

Leakage: Stray fields at 1 Mc/s are less than one microvolt per meter two feet from the generator.

Amplitude Modulation: 0 to 80%, continuously variable, indicated on the panel meter to $\pm 10\%$ of reading with possible additional error of 2% modulation.

Internal modulation frequency, 400 c/s $\pm 5\%$.

External modulation characteristic, for carrier frequencies above 400 kc/s, modulation is flat within ± 1 dB from 20 c/s to 15 kc/s; below 400 kc/s, modulation is flat within ± 1 dB from 20 c/s to 1 kc/s; 12 V into 4 k Ω required for 80% modulation.

Incidental Frequency Modulation: 30 to 300 ppm at 80% amplitude connection to type N, BNC, TNC, SC, C, or UHF connector, use a locking adaptor which locks securely in place, yet is easily removed. Panel connector is recessed, and adaptor projects only about an inch from panel.

Accessories Supplied: TYPE 874-R22LA Coaxial Cable, TYPE 1000-P1 50-Ohm Termination Unit, TYPE 1000-P2 40-Ohm Series Unit, TYPE 874-Q2 Adaptor, TYPE TO-44 Adjustment Tool (stored in cabinet), TYPE 274-MB Plug, TYPE CAP-22 Power Cord, spare fuses.

Accessories Available: TYPE 1000-P4 Standard Dummy Antenna, modulation, over all ranges except 15 to 50 Mc/s where it may be 3 times as great; approximately proportional to modulation percentage at low modulation percentages.

OUTPUT

Output Terminal	Voltage	Impedance
2 VOLTS Terminal	2 V, open circuit, up to at least 15 Mc/s, with output meter set to reference mark. Accuracy: $\pm 3\%$ at mid-frequencies.	300 Ω
ATTEN Terminal	0.1 μ V to 200 mV, open circuit; 0.05 μ V to 100 mV with output cable terminated at both ends; continuously variable. Accuracy: $\pm(6\% + 0.1 \mu$ V), 150 kc/s to 10 Mc/s with output dial near full scale or 1/10 full scale (error may be 4% greater with output dial set to mid-scale region); $\pm(10\% + 0.3 \mu$ V) above 10 Mc/s with output dial near full scale (error may be 10% larger or smaller at other output dial settings).	10 Ω ; 50 Ω when series unit is used; 50 Ω at highest output position of attenuator; 25 Ω at end of terminated cable.

GENERAL

Power Required: 105 to 125, 195 to 235, or 210 to 250 V, 40 to 60 c/s, 65 W; 115 to 125 V up to 400 c/s.

Terminals: GR874 Coaxial Connectors, recessed, locking. For the TYPE 1000-P10 Test Loop, TYPE 1750-A Sweep Drive.

MECHANICAL DATA Lab-Bench Cabinet

Width		Height		Depth		Net Weight		Shipping Weight	
in	mm	in	mm	in	mm	lb	kg	lb	kg
20¼	515	13¾	350	11	280	54	25	67	31

Type 1001-A Standard-Signal Generator

INTRODUCTION

The Type 1001-A Standard-Signal Generator covers the carrier-frequency range from 5 kc to 50 Mc. It may be amplitude-modulated up to 80% over the audio range from 20 c to 15 kc. The carrier output voltage at the attenuator jack is accurately adjustable to any value from 0.1 microvolt to 200 millivolts; output voltages up to two volts are available at a second jack.

Its major application is in the testing of radio receivers. It can also be used as an r-f voltage standard in field-intensity measurements. Its wide carrier-frequency range makes it suitable for use as a power source in bridge measurements and for measurements on supersonic equipment.

SECTION 1.0 OPERATION

1.1 POWER SUPPLY

The instrument is supplied complete with tubes and is ready for operation.

The line voltage and frequency are indicated on the nameplate above the power-input receptacle. The power-line-frequency range is 40 to 60 cycles. The voltage range is either 105 to 125 or 210 to 250 volts. The power-transformer connections are as shown in Figure 1. If it is desired to change from a 210-250-volt condition to a 200-240-volt condition, connect terminal #3 to terminal #2L rather than to terminal #2 (see Figure 1) and interchange the nameplates above the power-input receptacle to indicate the appropriate line voltage. Replace the fuses as specified in the parts list. The fuses are mounted inside the cabinet.

1.2 FREQUENCY CONTROLS

The two frequency controls are the FREQUENCY RANGE selector switch and the frequency dial. There are eight frequency ranges to cover the spectrum from 4.8 kc to 50 Mc. For rapid identification of the dial scale which corresponds to the selected frequency range, the dial scales and the selector switch segments are alternately etched with light figures on a black background and black figures on a light background except that the 15 - 50 Mc range is identified by a band of two parallel black lines.

For frequencies up to 15 Mc, the percentage frequency change is proportional to angular rotation. The vernier dial has been calibrated to indicate directly small percentage increments in frequency. Each division of this small dial corresponds to a 0.1% change in frequency except at the ends of the main frequency dial.

1.3 METER ZERO

With the power off, the meter should indicate zero. If it does not, it can be adjusted to zero by means of the screw-driver adjustment on the meter.

With the power ON, the CARRIER control in a full counter-clockwise position and the METER switch at CARRIER, the meter should also indicate zero. If it does not after a minute's warm-up period, and if the "mechanical zero" referred to in the preceding paragraph has been correctly set, the "electrical zero" may be set by means of the screw-driver adjustment available through the small panel hole near the OUTPUT dial (below the panel meter).

With the METER switch at MODULATION and the MODULATION control in a full counter-clockwise position, the meter will indicate zero if the "mechanical zero" referred to above has been correctly set.

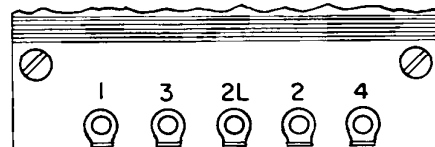

Connect #1 to #3 and #2 to #4
for 105 to 125 volt operation

Connect #2 to #3 for 210-250
volt operation

Connect #2L to #3 for 200-240
volt operation

Figure 1. Power Transformer Connections.

GENERAL RADIO COMPANY

1.4 OUTPUT SWITCH

Output voltage may be obtained either at the 2 VOLTS jack or at the ATTENUATOR jack. The desired jack is selected by the OUTPUT switch. To prevent leakage, the 2 VOLTS jack should be covered with its shielding cap when the output at the ATTENUATOR jack is used.

The OUTPUT switch is also used to control the cut-off frequency of a high-pass filter. When the lower index of the OUTPUT switch is at either of the two "OVER 400 KC" positions, modulation-frequency voltage in the output and at the carrier meter is reduced. At carrier frequencies less than 300 or 400 Kc, the OUTPUT switch must be set to one of the two positions beyond the sector marked "OVER 400 KC" and modulation-frequency voltage in the output can be quite high. See paragraphs 1.62 and 2.4.

1.5 OUTPUT ADJUSTMENT WITH NO MODULATION

To obtain output voltage at the ATTENUATOR jack a fixed carrier level must first be established at the input to the attenuator system by throwing the METER toggle switch to CARRIER and adjusting the CARRIER control until the meter pointer is deflected to the mid-scale point labelled "SET CARRIER". The open-circuit voltage at the ATTENUATOR jack is then continuously adjustable from 0.1 microvolt to 200 millivolts as shown by the reading of the OUTPUT dial (0 - 2.0) multiplied by the setting of the MULTIPLIER switch.

If the 2 VOLTS jack has been selected by setting the OUTPUT switch to either of the 2 VOLTS positions, the open-circuit voltage appearing at this jack is two volts when the meter is at SET CARRIER. This voltage may be varied by re-adjusting the CARRIER control to obtain the multiplying factors indicated (small numerals) either side of SET CARRIER, but this readjustment may cause a slight change in frequency and an increase in distortion as the output is increased.

1.6 OUTPUT ADJUSTMENT WITH MODULATION

1.61 Modulation Setting: As determined by the setting of the MODULATION switch, the modulating circuits may be connected for 400-cycle modulation from the internal source, for EXTERNAL modulation (20 to 15,000 cycles) or for no modulation. With the METER switch at MODULATION, the modulation level is indicated on the meter and can be adjusted by means of the MODULATION control to obtain any degree of modulation up to 80%. To provide 80% modulation, the external audio oscillator must be capable of supplying 12 volts into a 4000-ohm load (36 milliwatts).

1.62 Carrier Setting: With the high percentage modulation, the carrier level is reduced a small amount and must be reset by readjusting the CARRIER control if the modulating frequency is 400 cycles or less. At high

modulating frequencies, the audio-frequency component in the output voltage will affect the carrier meter reading (particularly when the OUTPUT switch is not at the "OVER 400 KC" sector). To avoid this error, first set the carrier level while using the internal 400 cps at the desired modulation level. Then switch to the external modulation and set the modulation to the desired level, but do not reset the carrier control. The carrier level will be correct even though the carrier meter will not so indicate.

1.7 OUTPUT IMPEDANCE

The output impedance at the ATTENUATOR jack is 10 ohms for all except the 100 MV MULTIPLIER setting, where the output impedance is 50 ohms.

CAUTION: Care must be taken to prevent the introduction of currents from the circuit under test into the attenuator, since excessive currents (greater than 50 milliamperes) may burn out the attenuator resistance cards.

The circuit impedance at the 2 VOLTS jack is approximately 300 ohms. With the OUTPUT switch at 2 VOLTS, the carrier meter is connected directly across the 2 VOLTS output jack and the effective output impedance is zero.

1.8 OUTPUT CONNECTIONS

When shielded connections are not required at low frequencies, open wires may be connected to the binding posts of the Type 874-Q2 Adaptor (supplied with the instrument) which may be plugged into either the ATTENUATOR or the 2 VOLTS jack. Similarly, a Type 274-MB Plug may be plugged into either output jack and its associated ground terminal.

At higher frequencies a shielded output cable should be used. The Type 874-R22A 3-foot Coaxial 50-Ohm Patch Cord is supplied for this purpose and may be plugged directly into either output jack. The Type 874-Q2 Adaptor may then be plugged into the output end of the patch cord to facilitate connections to the instrument under test; or better still, the Type 874-PB58 Panel Connector or the Type 874-C58A Cable Connector may be installed in the system under test to maintain coaxial connections throughout.

At frequencies above the broadcast range, proper cable termination becomes important. The 50-ohm patch cord is properly terminated at the generator end for the 100-millivolt position of the MULTIPLIER. At other MULTIPLIER positions, the patch cord is properly terminated if the Type 1000-P2 40-ohm Series Unit (supplied with the instrument) is plugged in between the ATTENUATOR jack and the patch cord. The open-circuit output voltage at the output end of the patch cord is still as indicated by the panel controls but the output impedance is now 50 ohms.

TYPE 1001-A STANDARD-SIGNAL GENERATOR

Throughout the range, but in particular at the highest frequencies (10 - 50 Mc), the patch cord may advantageously be terminated at its output end by plugging in the Type 1000-P1 50-ohm Termination Unit. This provides a net output impedance which is lower in value (25 ohms) and more constant with frequency. The output voltage, however, is one-half the voltage indicated by the panel controls.

The Type 874-R22A Patch Cord can be used at the 2 VOLTS jack for frequencies up to 2Mc but should not

be terminated.

1.9 SWEEP DRIVE. The Type 1001-A Standard Signal Generator can be swept over a frequency range up to a maximum of 14 percent by means of the Type 1750-A Sweep Drive, which attaches to the slow-motion dial. This Sweep Drive will sweep up to 300 degrees at speeds up to five sweeps per second. An oscilloscope-deflection-voltage circuit provides a horizontal deflection voltage proportional to shaft angle. A blanking circuit eliminates the return trace and produces a base line.

SECTION 2.0 CIRCUIT

2.1 DIAGRAMS

A block diagram is given in Figure 2 and the complete wiring diagram is shown in Figure 3.

2.2 SHIELDING

To reduce leakage and stray fields to a negligible level, the carrier-frequency circuits are contained in a completely closed radio-frequency compartment within the main cabinet. All leads to the radio-frequency compartment are carefully filtered. The two metal shafts that extend from the radio-frequency compartment to the outside of the instrument are well shielded. The cover to the radio-frequency compartment is of double construction with spring contacts bearing on both the inside and outside walls of the compartment.

2.3 CARRIER OSCILLATOR

As shown in the wiring diagram of Figure 3, the Hartley circuit is used in the carrier oscillator. The carrier-frequency range is determined by the setting of a turret which carries the eight range coils and some associated components.

To obtain a compact turret assembly, the coils are mounted alternately on either side of a disc. Each range covers a frequency span of 3.33 to 1 (4.8 to 16 and 15 to 50). The overall range is 4.8 kc to 50 Mc. Since the 100 $\mu\mu\text{f}$ grid-capacitor (C-4) is too small for the three low-frequency ranges (5 kc - 150 kc), additional capacitance (C-5, C-302) is automatically switched in. The resistor R-2 equalizes the load on the power supply.

The capacitance change of the main tuning capacitor (C-2) is about 750 $\mu\mu\text{f}$. The plates are shaped to yield a logarithmic frequency-calibration. To increase mechanical stability, the rotor plates are supported at an unusually large inside diameter. The 15 - 50 Mc range does not utilize the entire capacitance span of the main tuning-capacitor. The calibration for this range does not follow a logarithmic law and the percentage-frequency-change calibration of the vernier dial does not apply.

The oscillator tube is the Type 6C4 Miniature Triode. The amplitude of oscillation, and hence the final output level, are controlled by adjusting the regulated d-c plate-supply of the carrier oscillator by means of R-50, the tapered, 30 kilohm, CARRIER control. The 20 kilohm shunt resistor (R-51) at the CARRIER control equalizes the load on the power supply.

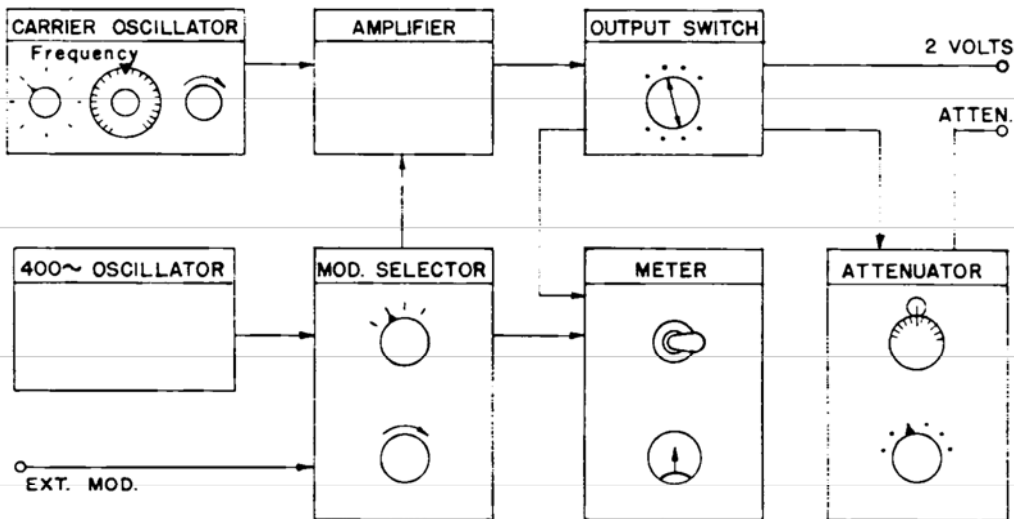

Figure 2. Functional Block Diagram.

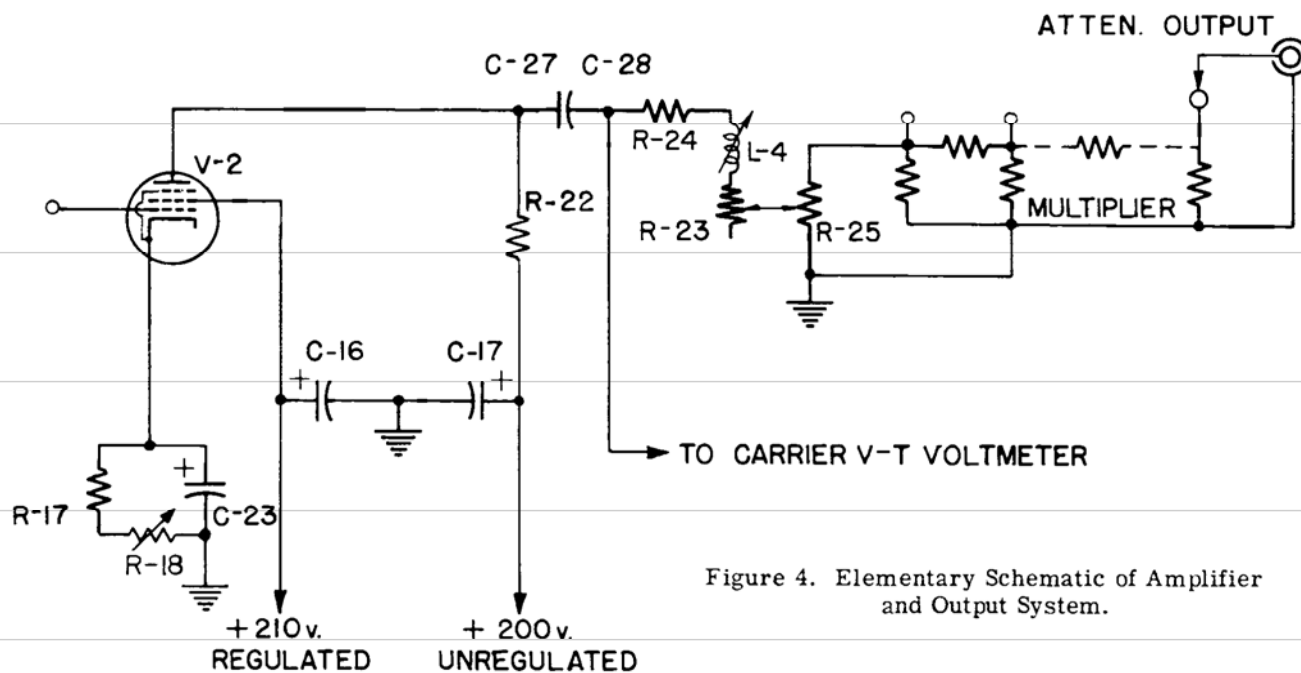

Figure 4. Elementary Schematic of Amplifier and Output System.

The carrier-frequency oscillator is coupled to the amplifier by means of an R-C network to provide the required driving voltage over the entire frequency range. Coupling at high frequencies is adjusted by the small trimmer capacitor C-21.

2.4 CARRIER AMPLIFIER

As shown schematically in Figure 4 and in more detail in the wiring diagram of Figure 3, the 6L6- or 1614-type beam-power-amplifier tube (V-2) is self-biased and operates as a class A amplifier. The bias due to the voltage drop in R-17 and R-18 is about -14 volts. The carrier voltage and the modulating voltage are coupled into the grid circuit of the amplifier tube. About 9 volts of audio-frequency voltage are required at the grid of V-2 to obtain 80% modulation. This corresponds to about 12 volts at the EXTERNAL MODULATION terminals. The carrier-frequency voltage required at the grid of V-2 to obtain full

output is about 1.6 volts over most of the mid-carrier-frequency range. The plate circuit therefore contains both carrier- and modulation-frequency voltages. To discriminate against modulation-frequency voltages in the signal-generator output and at the carrier voltmeter, coupling capacitor C-27 (500 $\mu\mu\text{f}$) is inserted in the plate circuit. Even so, the unwanted voltage can be half of the carrier-frequency voltage for 80% modulation at the maximum modulating frequency (15 kc). As the modulation level and frequency are reduced, the unwanted voltage is reduced rapidly; at 50% modulation and 400 cycles, it is down to one per cent of the carrier voltage. To pass low carrier frequencies which extend down to 5 kc, C-28, a capacitor of 0.01 μf , is added to C-27, and modulation-frequency voltage in the output circuit is increased by a factor of about twenty.

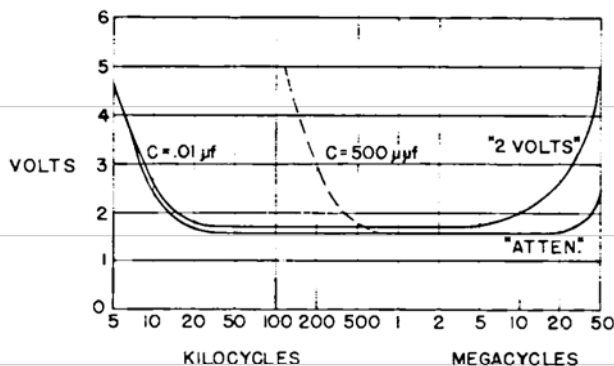

Figure 5. Carrier-Frequency Driving Voltage

The carrier-frequency voltage required at the grid of V-2 depends on the amplifier load and therefore is greater at the extreme ends of the frequency range, particularly at the high end, if the 2 VOLTS position of the OUTPUT switch has been selected. In the ATTENUATOR position, the load is about 330 ohms and consists of R-23 and R-24 in shunt with the carrier-voltmeter diode V-3a. In the 2 VOLTS positions, R-20 is switched in to obtain higher output; this increases the resistive component of the load to about 410 ohms. Since the coaxial cable leading to the 2 VOLTS jack is also switched in, the load is shunted by the comparatively large capacitance of the cable. For this reason, beyond 10 Mc the driving voltage required at the grid of the amplifier tube (V-2) increases with frequency as shown in Figure 5.

2.5 CARRIER VOLTMETER

A fixed-carrier level is established at the input

TYPE 1001-A STANDARD-SIGNAL GENERATOR

to the attenuator system by setting the CARRIER control (R-50) of the carrier oscillator to obtain a SET CARRIER reading on the panel meter. The carrier-voltmeter diode is connected from the high side of R-24 to ground (Figure 3) and yields a SET CARRIER reading at 1.6 volts. When the resistor R-20 is in circuit (OUTPUT switch at 2 VOLTS) the voltage from the high side of R-20 to ground is 2 volts. The carrier voltmeter is essentially a diode (V-3a) in series with the meter and a calibrating resistor; all components have been selected to give accurate calibration over the entire carrier-frequency range of the instrument. The "dummy" diode, V-3b, balances out the contact potential variations of the active diode. As a result, the zero adjustment and calibration are unaffected by normal line voltage variations. The two sections of the Type 6AL5 Miniature Twin-Diode V-3 serve as the "active" diode V-3a and the dummy diode V-3b of the carrier voltmeter. The electrical zero is adjusted by means of the voltage divider R-12 (a screw-driver adjustment that is available at the panel under the meter) and the sensitivity is adjusted by the rheostat, R-52, which is located inside the instrument.

2.6 ATTENUATOR SYSTEM

The attenuator system between the carrier voltmeter and the ATTENUATOR output jack consists of a continuously adjustable L-type network controlled by the OUTPUT dial and a six-position decade ladder network attenuator which serves as a MULTIPLIER.

The L-type network consists of an inductor (L4), a resistor (R-24), a linear calibrated voltage divider (R-25) and a taper-shaped rheostat (R-23), which maintains the input resistance of the network at 400 ohms as seen from the voltmeter.

Both the rheostat and the voltage divider are Ayrton-Perry wound to reduce the inductance to a minimum. In addition, the voltage divider is mounted on an aluminum block so that it does not act as a one-turn pickup loop when set for zero output.

The L-type network is mounted in the radio-frequency compartment. It is connected to the attenuator (which is mounted on the front panel) through a 274-type plug-and-jack mechanism to permit easy removal of the radio-frequency section from its compartment.

The individual resistors (R-30 through R-39) of the MULTIPLIER attenuator are wound in pairs on small mica cards. Some resistors are wound Ayrton-Perry fashion, and each pair of series and shunt resistors is carefully designed to proportion properly the residual inductances for flat frequency characteristic. The resistance cards are mounted in the segments of a cast housing; the switch contacts are built integrally in the casting for complete shielding between ladder network sections; the switch arm is further shielded from the input to the network by a metal block mounted in the cover of the attenuator housing.

The output impedance as seen at the ATTENUATOR jack is 10 ohms on all but the 100 MV position of the

MULTIPLIER where it is 50 ohms if the calibrated OUTPUT dial of the slide wire (R-25) is set for zero output. At other settings of the OUTPUT dial, the output impedance of the 100 MV position is somewhat less than 50 ohms and reaches a minimum of 43.75 ohms at full-scale setting. This change in output impedance has no effect on the open-circuit output voltage but when using an external termination, it is important to recognize that the impedance varies. Nominally, a 50-ohm termination will halve the output voltage. Actually, when using a 50-ohm termination for the 100 MV position of the MULTIPLIER only, the output voltage may be a maximum of $6-1/2\%$ high unless the following procedure is followed: adjust for SET CARRIER with the MULTIPLIER at any but the 100 MV setting; reset to the 100 MV position; it will be noted that the meter reading will be reduced at the high settings of the OUTPUT dial; if the CARRIER control is not readjusted, the output voltage will be correct.

2.7 MODULATION SYSTEM

The modulation system is shown in Figure 3. The modulating voltage may be obtained from the internal 400-cycle oscillator or from an external generator. The amount of modulation is controlled at the panel by the MODULATION voltage-divider (R-56) and is measured by a crystal-type voltmeter. The modulating voltage is then coupled to the grid of the modulating amplifier through a low-pass filter (see Figure 3).

The internal 400-cycle oscillator is of the R-C type where regeneration from plate to grid through a parallel-T network attenuates all but the desired frequency. The oscillator output is coupled to the grid of a cathode-follower stage and thence to the MODULATION selector switch (S-6). The two sections of a type 6SN7-GT twin-triode tube (V-7) serve as audio-oscillator and as amplifier.

The EXTERNAL MODULATION terminals are connected to the MODULATION selector switch through a low-pass filter which prevents carrier-frequency voltages from appearing at the terminals. With the MODULATION switch at EXTERNAL modulation (the worst condition) and the MODULATION control on full, the amount of carrier-frequency voltage at the EXTERNAL MODULATION terminals is about $10 \mu\text{v}$ at 150 kc and decreases very rapidly with frequency to less than $0.1 \mu\text{v}$ at frequencies above 250 kc. This rapid attenuation with frequency is due not only to the low-pass filter at the EXTERNAL MODULATION terminals but also to the R-C-L filters between the MODULATION control and the grid of the amplifier tube V-2.

The output from the MODULATION control is measured by a full wave rectifier system using two 1N34-AS germanium crystals, D-1 and D-2, and is indicated on the panel meter (M-1). The rheostat R-53 across the meter provides a means for adjusting the calibration, which extends from zero to 80% amplitude modulation.

The R-C filters at the meter terminals and a shield around the meter prevent carrier-frequency leakage.

GENERAL RADIO COMPANY

The audio voltage appearing at the grid of the 6L6- (or 1614-) type modulator tube (V-2) inside the r-f compartment must be exactly proportional to the audio voltage measured by the crystal-type modulation voltmeter which is mounted outside the r-f compartment. The two points are coupled through an R-C and L-C filtering network which has a flat frequency characteristic over the audio range up to 15kc and discriminates sharply against higher frequencies.

2.8 ACCESSORIES

All accessories use the universal Type 874 Coaxial Connectors which eliminate the mechanical matching difficulties inherent in conventional plug-and-jack designs.

The Type 874-R22A Patch Cord is a double-shielded 3-foot 50-ohm coaxial cable of approximately 32 $\mu\mu\text{f}$ per foot capacitance.

The Type 1000-P1 Termination Unit contains a 50-ohm resistor connected in shunt from the central conductor to the coaxial outer conductor. This unit is intended for proper termination of the Type 874-R22A Patch Cord at the output end.

The Type 1000-P2 Series Unit contains a 40-ohm resistor connected in series with the central conductor. This unit is used to increase the 10-ohm output impedance of the ATTENUATOR jack at all but the 100 MV position to 50-ohm output impedance for proper matching to the Type 874-R22A Patch Cord at the signal generator end.

The Type 874-Q2 Adaptor is used to connect leads to the two output jacks of the signal generator or to the output end of the Type 874-R22A Patch Cord.

SECTION 3.0 METHODS FOR RECEIVER TESTING

3.1 METHODS

Several methods for testing broadcast receivers have been recommended by the Institute of Radio Engineers (One East 79th Street, New York 21, New York) in the 1948 version of the Standards on Radio Receivers, **Methods of Testing Amplitude-Modulation Broadcast Receivers** and in the Standards published in the September, 1955 IRE PROCEEDINGS: "Method of Testing Receivers Employing Ferrite Core Loop Antennas." The test procedures include the use of a standard dummy antenna for testing receivers designed for a conventional overhead-type of antenna and a test loop for testing receivers designed for use with a loop antenna.

3.2 STANDARD DUMMY ANTENNA

When the receiver tests require the use of a standard dummy antenna, the Type 1000-P4 Standard Dummy Antenna (not supplied as standard equipment with the instrument) should be connected directly to the receiver antenna terminals (by means of the Type 874-Q2 Adaptor, if need be). The Type 1000-P4 Standard Dummy Antenna is built into a small cylindrical shield and gives the impedance-frequency characteristic shown in Figure 6 with the component values selected as shown in Figure 7 when working out of a 25-ohm impedance. The Type 1001-A Standard-Signal Generator provides the correct source impedance (25 ohms) when the patch cord is terminated with the Type 1000-P1 50-Ohm Termination Unit. For all but the 100 MILLIVOLT positions, the Type 1000-P2 40-Ohm Series Unit must be connected between the generator and the patch cord. Since the cable is terminated, the output voltage is one-half the voltage indicated by the panel settings.

At the highest frequencies (15 - 50 Mc), if coaxial connections cannot be maintained up to the receiver input terminals, errors in sensitivity measurements can result due to the reactance of the connecting leads. A method for introducing a measured amount of power into the receiver input terminals, in spite of appreciable lead reactance, is described in RCA APPLICATION NOTE number AN 132 of May 17, 1948, entitled, "Receiver Sensitivity and Gain Measurements at High Frequencies". In this method, when the receiver tuning capacitor and

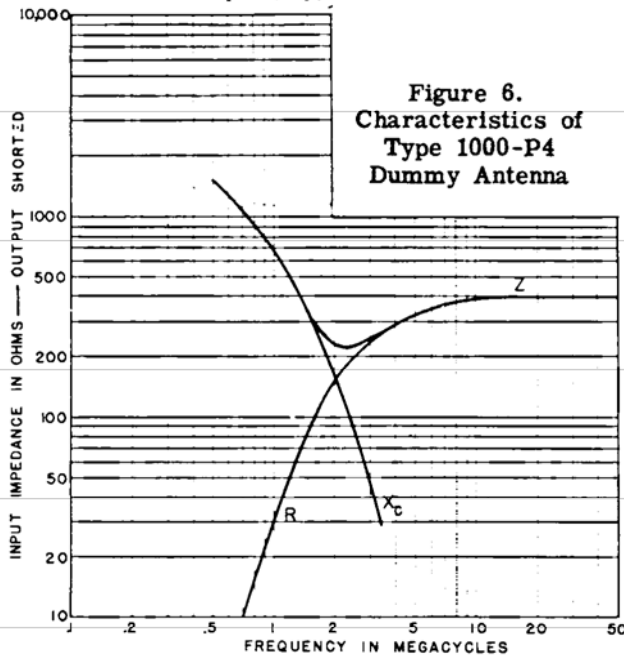

Figure 6.
Characteristics of
Type 1000-P4
Dummy Antenna

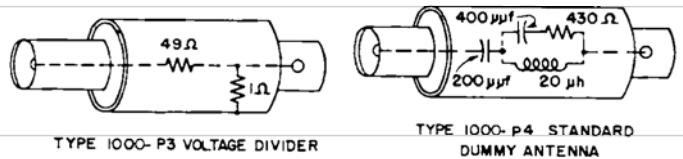

Figure 7.

TYPE 1001-A STANDARD-SIGNAL GENERATOR

an externally added series capacitor are both tuned for maximum receiver output, the receiver presents an effective input resistance which matches the dummy antenna resistance, and the input power may then be calculated.

3.3 LOOP ANTENNA - LOW IMPEDANCE METHOD

When the receiver under test is equipped with a loop antenna, it may be tested either with a transmitting test loop connected to the standard-signal generator or by introducing the test signal into the receiver loop through a very low impedance generator.

The Type 1000-P3 Voltage Divider (not supplied as standard equipment with the Type 1001-A Generator) was designed to facilitate the injection of a test signal in series with the receiver loop. The voltage divider is shown schematically in Figure 7. Its 50-ohm impedance at one end of the unit effectively terminates the Type 874-R22A 50-Ohm Coaxial Patch Cord and its one-ohm impedance at the other end of the unit is sufficiently low for insertion in series with the receiver's loop antenna without disturbing its normal operation. The voltage appearing at the one-ohm, or loop end of the voltage divider is one hundredth of the voltage indicated by the panel control settings (remember to use the Type 1000-P2 40-Ohm Series Unit at all but the 100 MV MULTIPLIER settings). **CAUTION:** This method is not recommended for use with the ac-dc type of receiver where one side of the power line is connected directly to the receiver chassis. There is considerable shock hazard if the signal generator is operated ungrounded; there is also the danger that the attenuator cards may be burned out.

3.4 LOOP ANTENNA - TEST LOOP METHOD

The Type 1000-P10 Test Loop (not supplied as standard equipment with the Type 1001-A Generator) provides a convenient means for measuring loop-antenna receivers in accordance with the preferred method outlined in the I.R.E. Standards mentioned above.*

The Type 1000-P10 Test Loop is an electrostatically shielded, three-turn coil of ten inches diameter. Figure 8 shows a schematic of the loop and its coupling

*See also "Measurement of Loop-Antenna Receivers" W. O. Swinyard, Proc. I.R.E., p. 382, July 1941 and "Calibration of Loop Antenna at VLF", A. G. Jean, H. E. Taggart, and J. R. Wait, Journal of Research of the National Bureau of Standards, C. Engineering and Instrumentation, Vol. 65, No. 3, July-September, 1961.

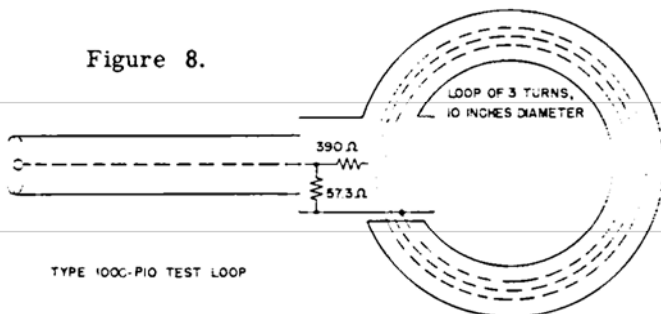

Figure 8.

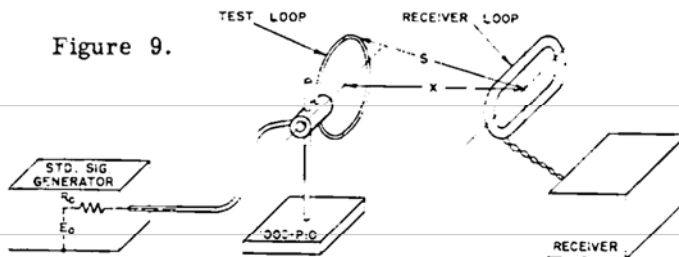

Figure 9.

circuit. The three-turn loop is connected to a four-foot coaxial cable by a 390-ohm resistor to assure constant loop current for a given input voltage up to 3 Mc. The 50-ohm cable is effectively terminated by the 50-ohm shunt combination of a 57.3-ohm shunt resistor and the 390-ohm series resistor. The input to the cable utilizes a Type 874-C Cable Connector.

Figure 9 shows the proper arrangement of apparatus for testing a loop-antenna radio-receiver with a standard-signal generator and the Type 1000-P10 Test Loop.

Note that the loops are arranged coaxially. The separation between the loops should be at least twice the greatest dimension of the larger loop.

The equivalent electric field intensity in microvolts per meter at the center of the receiving loop antenna is:

$$E = \frac{71,250}{(50 + R_0)S^3} E_0$$

Where E_0 is the open-circuit output voltage of the standard-signal generator in microvolts, R_0 (ohms) is the output impedance of the standard-signal generator, and S (inches) is the separation between the test loop and the receiving loop, as shown in Figure 9.

It is usually convenient to select the separation between loops so that the field intensity is readily expressed in terms of the signal generator voltage, E_0 . For example, when using the Type 1001-A Standard-Signal Generator with its 50-ohm output impedance, the field intensity in microvolts per meter at the receiver loop antenna is one-tenth of the open-circuit output voltage of the generator if the two loops are approximately one-half meter apart. Thus, when the signal generator open-circuit output voltage as indicated on the panel controls is 100 microvolts, the field intensity at the receiver loop is ten microvolts per meter.

Table I lists the loop spacing required under various generator impedance (R_0) conditions to obtain a convenient factor for determining the field intensity (E) at the receiving loop antenna in terms of the signal generator open-circuit output voltage, E_0 .

The separation "S" between loops is the distance between the outer periphery of the test loop and the center of the receiving loop. The separation "X" between loop centers is somewhat less, as shown in Table I.

TABLE I

R ₀	E ₀ /E	S (inches)	X (inches)
0 Ω	5	19.3	18.7
	10	24.2	23.7
	20	30.6	30.2
	50	41.5	41.1
	100	52.2	52.0
10 Ω	10	22.8	22.2
	20	28.8	28.4
	50	39.0	38.6
	100	49.2	49.0
37.5 Ω	10	20.1	19.4
	20	25.4	24.8
	50	34.4	34.0
	100	43.3	43.0
	200	54.6	54.3
50 Ω	10	19.3	18.7
	20	24.2	23.7
	50	32.9	32.5
	100	41.5	41.1
	200	52.2	52.0
75 Ω	20	22.5	22.0
	50	30.6	30.2
	100	38.5	38.1
	200	48.5	48.2

3.5 LOOP ANTENNA - TRANSMISSION-LINE METHOD

In this method, a transmission line is formed by stretching a single solid wire (#12 to #16 B and S gauge) between two insulators in a shielded room at a constant spacing from the ceiling. The transmission line is terminated at one end and fed from the standard-signal generator at the other end.

The method is described in the Appendix (Section 6.0) of the 1948 version of the IRE Standards referenced in paragraph 3.1 above.

Refer to Figure 10. The standard-signal generator is located outside the shielded room and is connected to the transmission line by means of a shielded cable grounded at the shielded room.

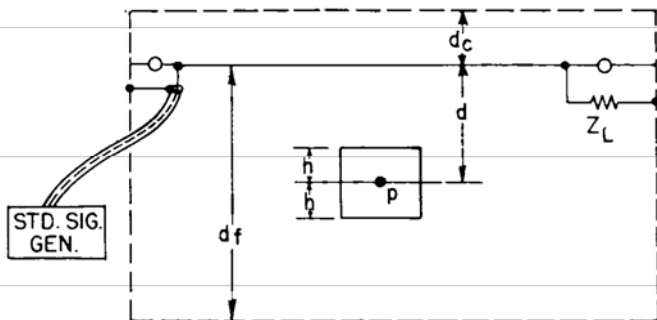

Figure 10.

The terminating resistance Z_L is equal to the line impedance

$$Z_L = Z_0 = 138 \log_{10} \frac{4 d_c}{a}$$

where "d_c" is the distance from the wire to the ceiling and "a" is the diameter of the wire. A 1000-ohm rheostat may be satisfactory as a termination. It is adjusted to the correct value when a vacuum-tube voltmeter indicates constant voltage (no standing waves) along the wire. This adjustment should be made at the highest operating frequency.

The field strength E in microvolts per meter at a point P directly below the center of the wire and near the center of the room is

$$E = \frac{60 E_g}{Z_g + Z_0} \left[\frac{1}{d} - \frac{1}{2d_c + d} + \frac{1}{2d_f - d} - \frac{1}{2d_f + 2d_c - d} + \frac{1}{2d_f + 2d_c + d} - \frac{1}{2d_f + 4d_c + d} + \frac{1}{4d_f + 2d_c - d} - \frac{1}{4d_f + 4d_c - d} \dots \dots \dots \right]$$

where E_g = signal generator output in microvolts
 Z_g = signal generator impedance
 d = distance in meters from wire to point P
 d_f = distance in meters from wire to floor
 d_c = distance in meters from wire to ceiling

If a square loop is used, the average field strength around the loop is approximately

$$E_{ave} = \frac{60 E_g}{Z_g + Z_0} \left[\frac{d}{2h} \log_e \frac{d+h}{d-h} \right] \left[\frac{1}{d} - \frac{1}{2d_c + d} + \frac{1}{2d_f - d} - \frac{1}{2d_f + 2d_c - d} \right]$$

where "2h" is the height of one side of the loop.

3.6 FERRITE-CORE LOOP ANTENNA

The Type 1000-P10 Test Loop (described in paragraph 3.4) is recommended for measuring ferrite-core loop-antenna receivers in accordance with the method outlined in the IRE Standard: "Method of Testing Receivers Employing Ferrite Core Loop Antennas."*

The correct arrangement of the apparatus is shown in Figure 11. The indicated orientation of the apparatus assures a substantially constant field at the ferrite-core loop antenna. Measurements should be carried out in a shielded room.

The equivalent electric field intensity in microvolts per meter at the receiver loop is

$$E = \frac{35,625}{(R_0 + 50)X^3} E_0$$

*PROCEEDINGS OF THE IRE, Vol 43, No. 9 (Sept., 1955) pp. 1086-1088.

TYPE 1001-A STANDARD-SIGNAL GENERATOR

where E_0 is the open-circuit output voltage of the standard-signal generator in microvolts, R_0 (ohms) is the output impedance of the standard-signal generator and

X is the distance (in inches) from the center of the Type 1000-P10 Test Loop to the center of the ferrite-rod loop antenna.

Table II lists the loop spacing required under various generator-impedance (R_0) conditions to obtain a convenient factor for determining the field intensity (E) at the receiving ferrite-rod loop antenna in terms of the signal-generator open-circuit voltage, E_0 , when using the Type 1000-P10 Test Loop.

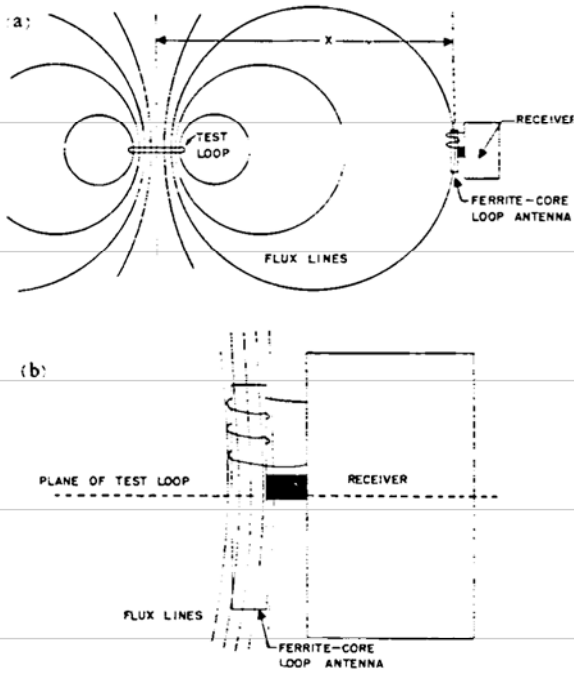

Figure 11.

TABLE II

R_0	E_0/E	$X(\text{inches})$	R_0	E_0/E	$X(\text{inches})$
0 Ω	5	15.3	37.5 Ω (Cont.)	50	27.2
	10	19.3		100	34.4
	20	24.2		200	43.4
	50	33.0	50 Ω	5	12.1
	100	41.5		10	15.3
200	52.2	20		19.3	
10 Ω	5	14.4	75 Ω	50	26.2
	10	18.1		100	32.9
	20	22.8		200	41.5
	50	31.0	5	11.2	
	100	39.0	10	14.1	
37.5 Ω	200	49.2	20	17.8	
	5	12.6	50	24.2	
	10	15.9	100	30.6	
	20	20.1	200	38.5	

SECTION 4. ACCESSORY AMPLITUDE MODULATOR

4.1 MODULATION METHODS

The Type 1001-A Generator is normally amplitude-modulated in the grid circuit of its amplifier tube (V-2). There is some incidental frequency modulation (see specifications). While the magnitude of incidental frequency modulation is relatively small, it may be excessive for some applications.

GENERAL RADIO COMPANY

SECTION 5.0 WIDE-BAND AMPLIFIER TESTS

5.1 EFFECT OF VARYING CARRIER DISTORTION

When a standard-signal generator is used in wide-band amplifier measurements, the usual test procedure is to set the generator voltage at the desired level as indicated by the attenuator settings and by the carrier meter in the generator; the amplifier output is then measured with an external meter. A gain-frequency curve plotted from data obtained from these measurements may exhibit discontinuities at those frequencies where the range switch position of the Type 1001-A Generator is changed. The discontinuities in indicated gain are due to differences in magnitude and character of the carrier distortion and percentage-wise may exceed appreciably the amount of distortion. The carrier meter in the generator is of the low impedance type with a response somewhere between average and positive peak. The response of the external meter may be any one of several types such as positive or negative peak, average, r.m.s., full-wave, half-wave, low or high impedance with consequent varying accentuation of the discontinuities.

Discontinuities and errors in gain measurements are reduced considerably or completely avoided by using the same meter (or two similar meters) to measure both the input and output voltages of the amplifier under test. The output system of the Type 1001-A Generator is well adapted to such a procedure, as outlined below, if complete shielding of the input to the amplifier is not required.

5.2 TEST PROCEDURE

Set the OUTPUT switch of the Type 1001-A Generator to 2 VOLTS. Connect the amplifier under test to the ATTENUATOR jack. Connect a high impedance voltmeter to the 2 VOLTS jack. Use this external meter rather than the internal carrier meter to monitor the input to the attenuator system; disregard the readings of the internal carrier meter. Adjust the CARRIER control to obtain 2 volts on the external meter. Set the OUTPUT dial and MULTIPLIER (attenuator) to the desired amplifier input voltage. Measure the amplifier output voltage with the same external meter or with another meter of similar response characteristics. The amplifier gain is the ratio of the amplifier output voltage to the signal generator output voltage as shown by the output dial and attenuator settings.

Amplifier gain-frequency curves plotted from data obtained by the above procedure will be free of discontinuities unless the amplifier under test introduces appreciable phase shifts. Since each amplifier stage normally produces a 180 degree phase shift, the external meter connections may have to be transposed at either the 2 VOLTS jack or at the amplifier output terminals when the amplifier consists of an odd number of stages. With some power-line operated meters, this transposition may introduce serious loading errors which can be avoided by using a battery operated instrument.

SECTION 6.0 SERVICE AND MAINTENANCE

6.1 WARRANTY. We warrant that each new instrument manufactured and sold by us is free from defects in material and workmanship, and that, properly used, it will perform in full accordance with applicable specifications for a period of two years after original shipment. Any instrument or component that is found within the two-year period not to meet these standards after examination by our factory, District Office, or authorized repair agency personnel will be repaired or, at our option, replaced without charge, except for tubes or batteries that have given normal service.

6.2 SERVICE. The two-year warranty stated above attests the quality of materials and workmanship in our products. When difficulties do occur, our service engineers will assist in any way possible. If the difficulty cannot be eliminated by use of the following service instructions, please write or phone our Serv-

ice Department (see rear cover), giving full information of the trouble and of steps taken to remedy it. Be sure to mention the type and serial numbers of the instrument.

Before returning an instrument to General Radio for service, please write to our Service Department or nearest District Office, requesting a Returned Material Tag. Use of this tag will ensure proper handling and identification. For instruments not covered by the warranty, a purchase order should be forwarded to avoid unnecessary delay.

6.3 DISASSEMBLY AND REASSEMBLY.

6.3.1 REMOVAL OF INSTRUMENT FROM CABINET. To remove the instrument from the cabinet, unfasten all bright-nickle-plated machine screws along the edges of the panel (16 screws in all). When the instrument is re-

placed in the cabinet, tighten all these screws equally to minimize r-f leakage. A recommended torque to be applied to these screws is 15 inch-pounds.

6.3.2 REMOVAL OF R-F UNIT. Remove the spring-held shielded cover on the rear of the r-f section by pushing it away from the panel. The r-f unit is so designed that it can be operated outside of the instrument, by the use of a built-in interconnecting cable, which is wound on the front of the r-f unit. Should the r-f unit be removed, frequency calibration and output dial readjustment will be necessary when the r-f unit is returned to the instrument. Before any disassembly is undertaken, set the attenuator MULTIPLIER to 100 millivolts and the output dial to exactly 1.0. Then proceed as follows:

- a. With an accurate bridge that can measure to the nearest hundredth of an ohm, measure the d-c resistance between the high side of the ATTENUATOR terminal and the contact arm of R23, the potentiometer mounted on the r-f unit. Record this value, which will be used later for resetting the output dial correctly. The value of d-c resistance will be in the vicinity of 36.50 ohms.
- b. Remove the output dial, OUTPUT knob, FREQUENCY RANGE knob, and associated parts.
- c. To remove the main frequency dial, first unfasten the two screws holding the dial cover plate and knob assembly. Lift off the cover plate and remove the main dial by loosening the setscrews in the hub.
- d. Disconnect the cable leading from the two-volt terminal to the r-f compartment by loosening the feed-through bushing and the screw terminal connection inside the r-f compartment.
- e. Remove the four large screws from the tubular standoffs at the rear of the r-f shelf.
- f. Pull out the r-f unit.
- g. If the two screws that mount the seven-terminal plug plate on the r-f unit are removed, the plug plate can be connected to the instrument and the r-f unit can be operated outside of the instrument for easier servicing.

6.3.3 REASSEMBLY.

- a. Before replacing the r-f unit in the compartment, wind the service cable back onto the supports provided. Remount the seven-terminal plug plate.
- b. Fasten the r-f unit in the compartment and note if any shaft binds. If there is bind, loosen and retighten the panel screws that hold bearing plates coaxially about the shafts.
- c. Replace the two-volt cable and bushing.
- d. Replace FREQUENCY RANGE and OUTPUT knobs. Make sure that the insulated sleeve, bakelite block, spring washer and 3/4-in. collar are mounted on the frequency range selector shaft. The flat on the shaft indicates the arrow side of the knob.
- e. Mount frequency range knob assembly as flush as possible to the panel to minimize r-f leakage.
- f. Mount the main frequency dial, insulated sleeve, and spring washer. Slightly tighten one of the set screws on the dial hub. Set the main tuning capacitor to full mesh by butting the rotor plates against a straight-edge

held firmly on the stator plates. Slip the frequency dial until the reference line on the dial lines up with the hair-line on the indicator. The reference line is located on the dial, six degrees below the lowest frequency mark. Tighten the dial setscrews, making sure that the dial assembly is flush with the panel. Attach the cover plate.

g. Mount the spring washer and the 5/16-in. collar on the output control shaft. With the attenuator MULTIPLIER at the 100-millivolt position, set the output control to the previously recorded value of resistance. Return the output dial to the shaft and set it for a reading of 1.0. Be sure that the dial assembly is tightened as flush as possible to the panel to minimize r-f leakage.

6.4 TROUBLE-SHOOTING.

6.4.1 INSTRUMENT INOPERATIVE.

- a. Check that the pilot light and all tube filaments are lighted.
- b. Test V1, V2, V3, V4, and V7. The voltage regulator tubes V5 and V6 should emit a steady glow.
- c. Measure voltages on transformer T1 (see Table 1).
- d. Check that resistors R47, R48, and R49 are not open-circuited.
- e. Measure tube voltages (see Table 2).
- f. Measure resistances (see Table 3).

6.4.2 GENERATOR DRAWS EXCESSIVE POWER AND BLOWS FUSES.

- a. Inspect the power supply for short circuits.
- b. Test the Type 5Y3 rectifier tube V4 for internal shorts.
- c. Check filter capacitors C34 through C38 for short circuits or low leakage resistances.
- d. Check all plate supply wiring for broken insulation and visible short circuits.
- e. Check that capacitors C8, C9, C10, C11, C12, and C14 are not shorted.

6.4.3 NO CARRIER READING.

- a. Inspect the action of all contacts on the coil turret mechanism. These should operate properly for both directions of turret rotation. Check the oscillator coils with an ohmmeter for continuity.
- b. Test V1, V2, and V3.
- c. Measure the output of the oscillator from pin 1 of the Type 6C4 tube V1 to ground with a vacuum-tube voltmeter, such as GR Type 1800-B. Output should be approximately 7 volts ac (at 1 megacycle).
- d. Check voltages of V1, V2, and V3.
- e. Check capacitors C16, C17, and C18 for short-circuits.
- f. If there is output and the meter does not read, check V3. If V3 is all right and there is no carrier indication, test the meter. DO NOT CHECK METER CONTINUITY WITH AN OHMMETER. The meter will read full scale on 200 microamperes of direct current.
- g. If the carrier meter is defective, a replacement should be ordered from the General Radio Service Department. General Radio Company cannot assume responsibility for any local repairs to the meter, although such repairs may be necessary in an emergency.

GENERAL RADIO COMPANY

6.4.4 CARRIER OUTPUT ERRATIC.

- a. Check the action of all finger contacts on the coil turret. Look for foreign matter and dirt on the contact surfaces.
- b. Clean out any foreign matter that may be lodged between plates of the main tuning condenser C2.
- c. Inspect the operation of the wiping contact on the main tuning condenser C2.
- d. Check that voltage regulator tubes V5 and V6 are operating with a steady glow. (Voltage regulator tubes may flicker on abnormally low line voltages.)

Frequency	Inductor Core Adjustment (hex-wrench adjustment)	Trimmer Adjustment (screw-driver adjustment)
5-15kc	hole A	hole B
15-50kc	D	C
50-150kc	A	B
150-500kc	D	C
0.5-1.5Mc	A	B
1.5-5.0Mc	D	C
5-15Mc	A	B
15-50Mc	D	C

6.4.5 NO MODULATION READING ON METER.

a. With a suitable means of detection (radio receiver or cathode-ray oscilloscope) determine the presence of modulation on the carrier. If the carrier is modulated but the meter does not read, measure the front and back resistances of the crystal diodes D1 and D2. The ratio of front to back resistance is approximately 1 to 50 (measured on the X100 Ω scale of a multimeter). Replace any diode that exhibits a low front to back resistance ratio. If there is no reading on both the carrier and modulation positions and output exists, check the meter. DO NOT USE AN OHMMETER IN CHECKING METER CONTINUITY. The meter will read full scale with 200 microamperes of direct current applied. Refer to paragraph 6.4.3g.

b. If the meter does not read and the carrier is not modulated, test the oscillator-amplifier tube V7. Measure resistors R65, R66, R67 and capacitors C43, C44, and C45.

The procedure for frequency calibration is as follows:

a. First adjust the low-frequency end of a given range with the appropriate inductor core adjustment. A hex wrench (Tool No. TO-44), provided for this purpose, is clip-mounted inside the cabinet. Turning the core clockwise results in a corresponding decrease in frequency at a given point on the dial. In other words, if the actual frequency falls below its calibrated point on the dial, a clockwise adjustment will bring the frequency and the calibration into agreement.

b. When the low end of the range is satisfactorily adjusted, tune the instrument to the high end of the range and note relative positions of various frequencies with respect to calibrated points on the dial. A screw-driver adjustment of the trimmer condensers will bring the frequency and the calibration into agreement.

c. Spot check various frequencies along the dial to determine over-all accuracy. Repeat calibration procedure if necessary.

6.4.6 NO MODULATION OF CARRIER (METER READS).

a. If no modulation appears in the output, measure the grid voltage at pin 5 of V2 with a vacuum-tube voltmeter. Voltage should be approximately 11 volts for 80% modulation. Test V2.

b. Measure the voltage across C14. It should be at least 12 volts for 80% modulation.

6.6 TUBE REPLACEMENT. If the 6C4 oscillator tube (V1) is replaced, the frequency calibration at the high-frequency end of each range may need adjustment. Refer to paragraph 6.5 for procedure.

The filaments of replacement 6AL5 voltmeter tubes (V3) should be aged for at least 24 hours. Upon replacement it may be necessary to recalibrate the voltmeter.

6.4.7 ERRATIC MODULATION.

a. Replace tube V2. The replacement for this tube must be selected for low distortion.

b. Check capacitors C8, C9, C10, C11, C12, C14, C16, C17, C18, and C23.

The procedure is as follows:

a. Adjust the meter mechanical zero.

b. Turn on the power, set the METER switch to CARRIER, the frequency to 600 kc, and the OUTPUT switch to 2 volts over 400 kc. Short-circuit resistor R20 and allow the instrument to warm up before making any adjustments. Resistor R20 is mounted on switch S2.

c. Adjust the electrical zero, and connect a carefully calibrated rms-reading vacuum-tube voltmeter to the 2-VOLT OUTPUT jack. Adjust CARRIER control for 1.52 volts at the vacuum-tube voltmeter. Adjust potentiometer R52 (located at the rear of instrument and labeled "CARRIER") to obtain a panel-meter reading at the SET CARRIER line. Recheck the electrical zero.

d. Remove the short-circuit from across resistor R20, reset the CARRIER control to obtain "SET CARRIER" reading on panel meter and check that the vacuum-tube voltmeter reads 1.9 volts $\pm 3\%$.

6.4.8 MEASUREMENT OF ATTENUATOR RESISTORS. Set the OUTPUT dial to zero and the OUTPUT switch to ATTENUATOR. Measure the d-c resistance across the ATTENUATOR output with an accurate bridge. It should be 50 Ω $\pm 1.5\%$ on the 100-millivolt position and 10 Ω $\pm 0.75\%$ on the other multiplier settings.

6.5 FREQUENCY CALIBRATION. Frequency adjustments can be made through holes found under a spring strap in the top of the r-f compartment shield. The adjustments for the various frequency ranges are found as follows:

TYPE 1001-A STANDARD-SIGNAL GENERATOR

6.7 VOLTAGE MEASUREMENTS.

TABLE 1

Transformer T1 Voltage Measurements
Between

Term. No.	Term. No.	A-c Volts
11	13	630
14	16	4.3
17	18	6.3
11	Ground	315
13	Ground	315
14	Ground	700
15	Ground	700
16	Ground	700

TABLE 2
Voltage Chart

Tube, Type	RANGE	Pin. No.								Tube Function
		1	2	3	4	5	6	7	8	
V1 (6C4)	5-15kc	25	-	6.0vdc	0	-	-3.5	0.1		R-F OSC
	15-50kc	15	-	6.0vdc	0	-	-2.5	0.1		
	50-150kc	17	-	6.0vdc	0	-	-2.7	0.1		
	150-500kc	23	-	6.0vdc	0	-	-2.4	0.1		
	0.5-1.5Mc	32	-	6.0vdc	0	-	-10.0	0.2		
	1.5-5Mc	34	-	6.0vdc	0	-	-5.5	0.2		
	5-15Mc	62	-	6.0vdc	0	-	-3.5	0.6		
15-50Mc	112	-	6.0vdc	0	-	-1.6	1.4			
V2 (6L6 or 1614)	(7.5vac) 0.5-1.5Mc	0	6.0vdc	143 (2.2vac)	205	0 (0.8vac)	0	0	15.5	MIXER AMPLIF
V3 (6AL5)	0.5-1.5Mc	0.54	-0.06	6.0vdc	0	1.6	0.1	0.4		VTVM DIODE
V4 (5Y3)	0.5-1.5Mc	-	330	-	300vac	-	300vac	-	330	RECT
V5 0C3)	0.5-1.5Mc	-	107	-	-	212	-	-	-	REG
V6 (0C3)	0.5-1.5Mc	-	0	-	-	107	-	-	-	REG
V7 (6SN7)	0.5-1.5Mc									AUDIO OSC and AMPLIF
	400~Mod.On	0	81	2.5	58	260	118	6.0vac	0	
	Mod. Off	0	66	2.7	58	270	120	6.0vac	0	

NOTES

- Line voltage 115v, 60 cps
- Voltages dc unless otherwise specified.
- Measure with vacuum-tube voltmeter (GR Type 1800 recommended)
- Range settings as noted.
- Modulation frequency 400 cps, with 80% modulation.
- CARRIER pot. - to SET CARRIER line on each range.
- OUTPUT switch at appropriate ATTENUATOR setting.
- Output slide wire set to zero.
- MULTIPLIER - 100 mv
- Main tuning dial set to 100 on outer scale.

TYPE 1001-A STANDARD-SIGNAL GENERATOR

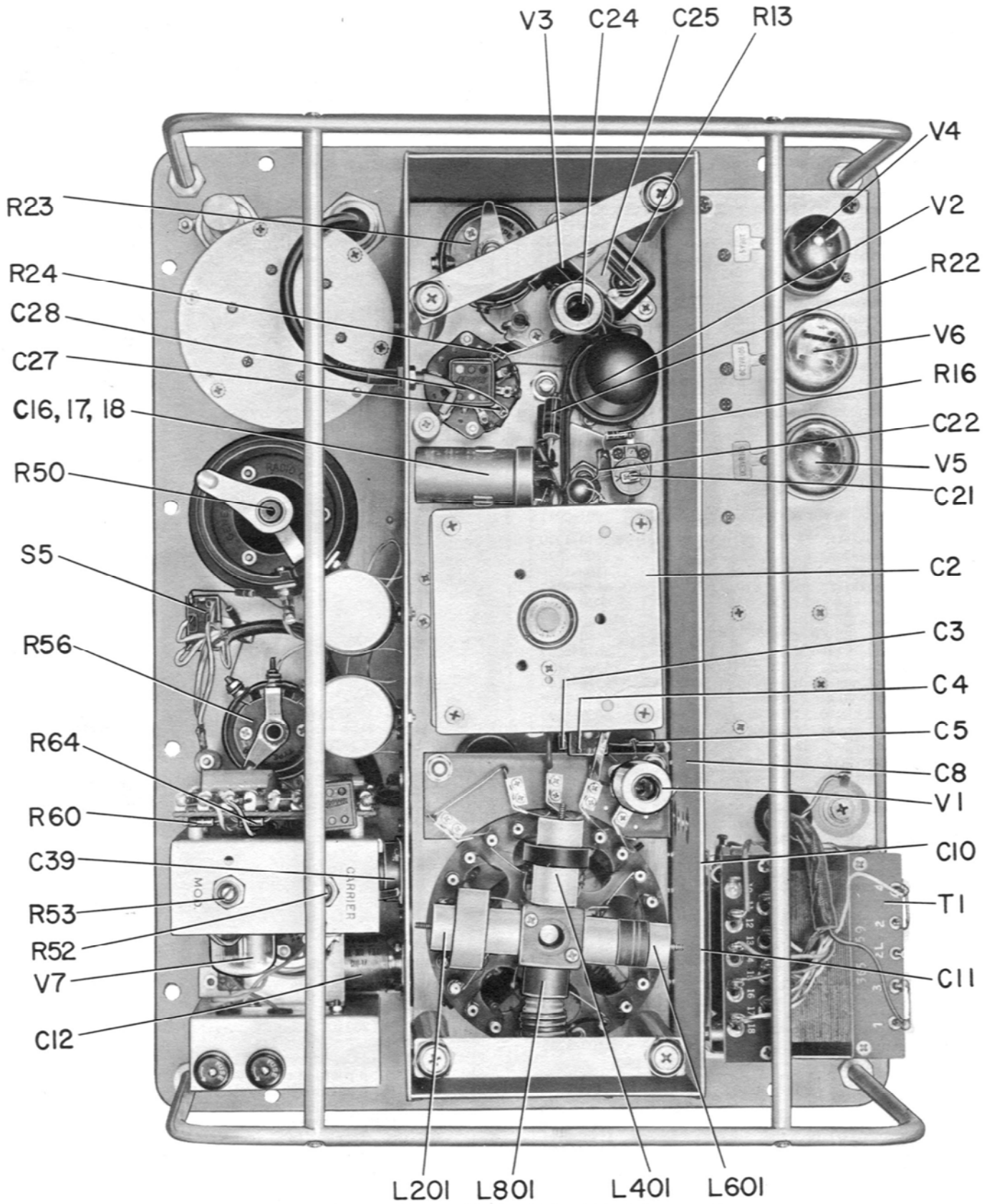

Rear Interior View with Oscillator Shield Cover off.

PARTS LIST

Ref No.	Description	Part No.
RESISTORS		
R2	Composition, 47 kΩ ±10%	6110-3479
R3	Composition, 300 Ω ±5%	6100-1305
R4	Composition, 100 kΩ ±5%	6100-4105
R6	Composition, 270 Ω ±5%	6100-1275
R7	Composition, 270 Ω ±5%	6100-1275
R8	Composition, 270 Ω ±5%	6100-1275
R9	Composition, 560 Ω ±5%	6100-1565
R10	Composition, 33 kΩ ±5%	6100-3335
R11	Composition, 270 Ω ±5%	6100-1275
R12	Potentiometer, Wire-wound, 1 kΩ	6050-1300
R13	Film, 8.25 kΩ ±1%	6450-1825
R14	Composition, 5.1 kΩ ±5%	6100-2515
R15	Composition, 56 kΩ ±5%	6100-3565
R16	Composition, 750 kΩ ±5%	6100-4755
R17	Composition, 300 Ω ±5%	6100-1305
R18	Potentiometer, Composition, 100 Ω ±10%	6040-1730
R19	Composition, 560 kΩ ±5%	6100-4565
R20	Composition, 82 Ω ±5%	6100-0825
R21	Film, 5.6 kΩ ±1%	6350-1560
R22	Composition, 1 kΩ ±5%*	6120-2205
R23	Potentiometer, Wire-wound, 50 Ω	0432-3052
R24	Wire-wound, 350 Ω ±1/2%	1001-0290
R25	Potentiometer, Wire-wound, 95 Ω	0432-3040
R30		
R31	Resistance unit of Attenuator Assembly	1001-2013
R32		
	through Resistance unit of Attenuator Assembly	1001-2012
R37		
R38		
R39	Resistance unit of Attenuator Assembly	1001-2011
R41	Wire-wound, 15 Ω ±10%	part of 7510-1930
R42	Composition, 6.2 kΩ ±5%	6100-2625
R43	Composition, 560 Ω ±10%	6100-1565
R44	Composition, 560 Ω ±10%	6100-1565
R45	Power, 1.6 kΩ ±10%	6630-2169
R46	Power, 1.6 kΩ ±10%	6630-2169
R47	Power, 1.5 kΩ ±10%	6630-2159
R48	Power, 1 kΩ ±10%	6630-2109
R49	Composition, 100 Ω ±10%	6760-1335
R50	Potentiometer, Wire-wound 30 kΩ ±5%	0371-4160
R51	Power, 20 kΩ ±10%	6620-2000
R52	Potentiometer, Wire-wound, 5 kΩ	6050-1700
R53	Potentiometer, Composition, 20 kΩ	6010-1000
R54	Composition, 22 kΩ ±5%	6100-3225
R55	Composition, 22 kΩ ±5%	6100-3225
R56	Potentiometer, Wire-wound 20 kΩ	0301-4310
R57	Composition, 10 kΩ ±5%	6100-3105
R58	Composition, 470 kΩ ±5%	6100-4475
R59	Composition, 180 Ω ±5%	6100-1185
R60	Composition, 2.2 MΩ ±5%	6100-5225
R61	Composition, 27 kΩ ±10%	6110-3279
R62	Composition, 1 MΩ ±5%	6100-5105
R63	Composition, 1 kΩ ±5%	6100-2105
R64	Composition, 680 kΩ ±5%	6100-4685
R65	Film, 107 kΩ ±1%	6450-3107
R66	Film, 517 kΩ ±1/2%	6450-3517
R67	Film, 517 kΩ ±1/2%	6450-3517
R68	Composition, 100 Ω ±5%	6100-1105
R69	Composition, 2.4 kΩ ±5%	6100-2245
R70	Composition, 120 kΩ ±5%	6100-4125
R101	Composition, 47 kΩ ±5%	6100-3475
R201	Composition, 33 kΩ ±5%	6100-3335
R301	Composition, 24 kΩ ±5%	6100-3245

CAPACITORS

C2	Variable, Air 21-820 pF	0848-4040
C3	Mica, 0.002 μF ±10%	4720-0600
C4	Mica, 100 pF ±10%	4660-2900
C5	Mica, 0.01 μF ±10%	4760-0100
C6	Oil, 0.47 μF +20 -10%	4512-4479
C7	Oil, 0.47 μF +20 -10%	4514-4479
C8		
	through Oil, 0.47 μF +20 -10%	4514-4479
C12		
C14	Ceramic, 470 pF	4400-2000
C15	Ceramic, 220 pF	4400-1950
C16	Electrolytic, 10 μF +70 -10%	4460-0200
C17	Electrolytic, 10 μF +70 -10%	4460-0200

Ref No.	Description	Part No.
CAPACITORS (cont)		
C18	Electrolytic, 5 μF +70 -10%	4460-0200
C20	Ceramic, 220 pF ±10%	4400-1950
C21	Trimmer, 1.5-7 pF	4910-0300
C22	Oil, 0.47 μF ±10%	4510-4200
C23	Electrolytic	4450-1000
C24	Mica, 500 pF 50 V	4660-5600
C25	Oil, 0.05 μF ±10%	4510-0050
C27	Mica, 500 pF ±10%	4660-5600
C28	Mica, 0.01 μF ±10%	4760-0100
C30	Unclassified, 0.01 μF +20 -10%	4920-1200
C31	Unclassified, 0.01 μF +20 -10%	4920-1200
C32	Electrolytic, 3000 μF +100 -10%	4450-0700
C33	Electrolytic, 3000 μF +100 -10%	4450-0700
C34	Electrolytic, 20 μF +50 -10%	4460-0900
C35	Electrolytic, 20 μF +50 -10%	4460-0900
C36	Electrolytic, 20 μF +50 -10%	4460-0900
C37	Electrolytic, 20 μF +50 -10%	4460-0900
C38	Electrolytic, 20 μF +50 -10%	4450-0300
C39	Oil, 0.5 μF ±10%	4510-0500
C40	Mica, 200 pF ±10%	4660-3801
C41	Mica, 0.001 μF ±10%	4660-6400
C42	Oil, 0.02 μF ±10%	4510-2400
C43	Mica, 0.001 μF ±1%	4730-0100
C44	Mica, 0.001 μF ±1%	4730-0100
C45	Mica, 0.002 ±1%	4730-0200
C46	Oil, 0.02 μF ±10%	4510-2400
C47	Mica, 200 pF ±10%	4660-3801
C48	Mica, 200 pF ±10%	4660-3801
C101	Trimmer, 5-20 pF	4910-0400
C201	Trimmer, 7-45 pF	4910-0100
C301	Trimmer, 7-45 pF	4910-0100
C302	Mica, 125 pF ±10%	4660-3100
C401	Trimmer, 7-45 pF	4910-0100
C501	Trimmer, 7-45 pF	4910-0100
C601	Trimmer, 7-45 pF	4910-0100
C701	Trimmer, 7-45 pF	4910-0100
C801	Trimmer, 5-20 pF	4910-0400

MISCELLANEOUS

D1	DIODE, Type 1N34	6082-1003
D2	DIODE, Type 1N34	6082-1003
D3	DIODE, Type 1N3492	6081-1005
F1	FUSE, 0.8 A Type 3AG Slo-Blo	for 115 V 5330-1200
F2	FUSE, 0.8 A Type 3AG Slo-Blo	
F1	FUSE, 0.4 A Type 3AG Slo-Blo	for 230 V 5330-0900
F2	FUSE, 0.4 A Type 3AG Slo-Blo	
J1	CONNECTOR, Type 874 ATTEN	0874-2000
J2	CONNECTOR, Type 874 2 VOLTS	0874-2000
J3	BINDING POST, EXT MOD	4060-0100
L1	INDUCTOR, 250 mH	0119-0301
L3	INDUCTOR, 60 mH	1001-0270
L4	INDUCTOR, 1.0-1.6 μH	4290-3900
L101	INDUCTOR, 1.335 mH	1001-2220
L201	INDUCTOR, 137 mH	1001-2052
L301	INDUCTOR, 13.35 mH	1001-2053
L401	INDUCTOR, 1.37 μH	1001-2054
L501	INDUCTOR, 133.5 μH	1001-2055
L601	INDUCTOR, 13.5 μH	1001-2060
L701	INDUCTOR, 1.1 μH	1001-2070
L801	INDUCTOR, 0.13 μH	1001-2080
M1	METER, 200 μA	5730-1377
P1	PILOT LIGHT, Mazda #44	5600-0700
PL1	POWER PLUG, 3-prong male connector	4240-0700
S1	SWITCH, 8 position rotary FREQ RANGE	1001-3050
S2	SWITCH, 4 position rotary OUTPUT	7890-0370
S3	SWITCH, 6 position rotary MULTIPLIER	
	part of Attenuator Assembly	1001-0390
S4	SWITCH, Toggle, DPST (connected mechanically to S6) power	7890-0360
S5	SWITCH, Toggle, DPDT METER	7910-1500
S6	SWITCH, 4 position rotary MULTIPLIER	7890-0360
T1	TRANSFORMER, power	0365-4592
V1	TUBE, Type 6C4	8360-3800
V2	TUBE, Type 6L6/1614	8380-1614
V3	TUBE, Type 6AL5	8360-1000
V4	TUBE, Type 5Y3-GT	8350-0400
V5	TUBE, Type OC3	8300-0500
V6	TUBE, Type OC3	8300-0500
V7	TUBE, Type 6SN7-GT	8360-7100

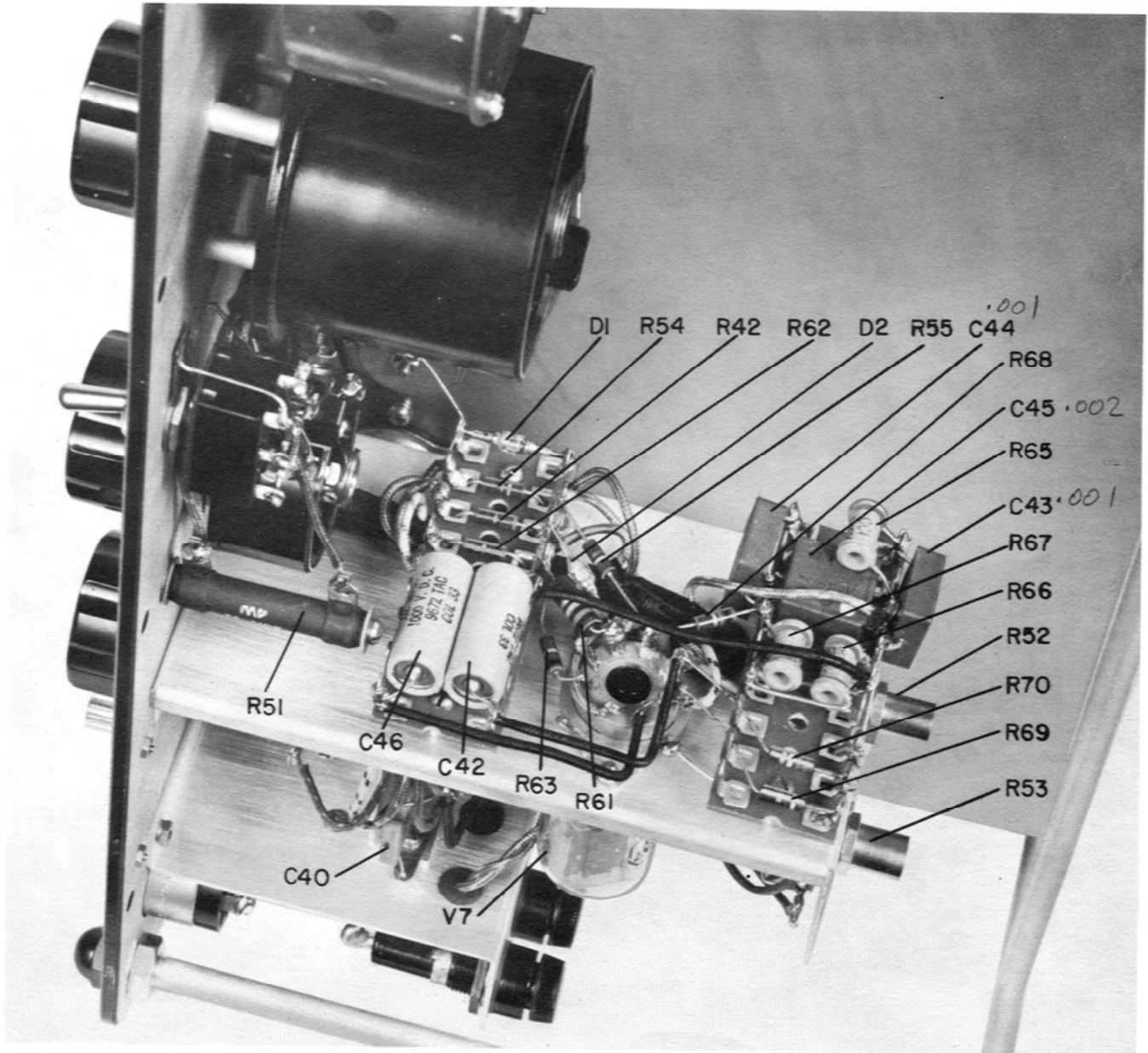

Modulator Shelf.

GENERAL RADIO COMPANY

TABLE 3
Resistance Chart

Tube	Pin. No							
	1	2	3	4	5	6	7	8
V1	280*	-	0	0	-	100k	300	
V2	0	0	7.5k	280	65k	10k**	0	360
V3	6k	400	0	0	∞	1k	∞	
V4	-	3k	-	120	-	120	-	3k
V5	-	∞	-	-	0	-	-	
V6	-	0	-	-	∞	-	-	
V7	10M	130k	2.6k	1.5M	4.5k	28k	0	

*Except for three lowest ranges which are 50k, 35k, and 25k for 5-15 kc, 15-50kc, and 50-150kc respectively.

**Anchor terminal.

Resistances in ohms unless otherwise specified by k (kilohms) or M (megohms). Measurements made with 20,000-ohm/volt multimeter.

Connect a lead from pin 5 of V5 to ground when checking resistances.

Make all measurements from tube socket pins to ground, with tubes removed.

SWITCH POSITIONS

FREQ RANGE - 150-500 kc

METER - MODULATION

MODULATION - 400~

OUTPUT - ATTEN

MODULATION - full clockwise

Output Pot. - set to zero

CARRIER - full clockwise

MULTIPLIER - 100mv

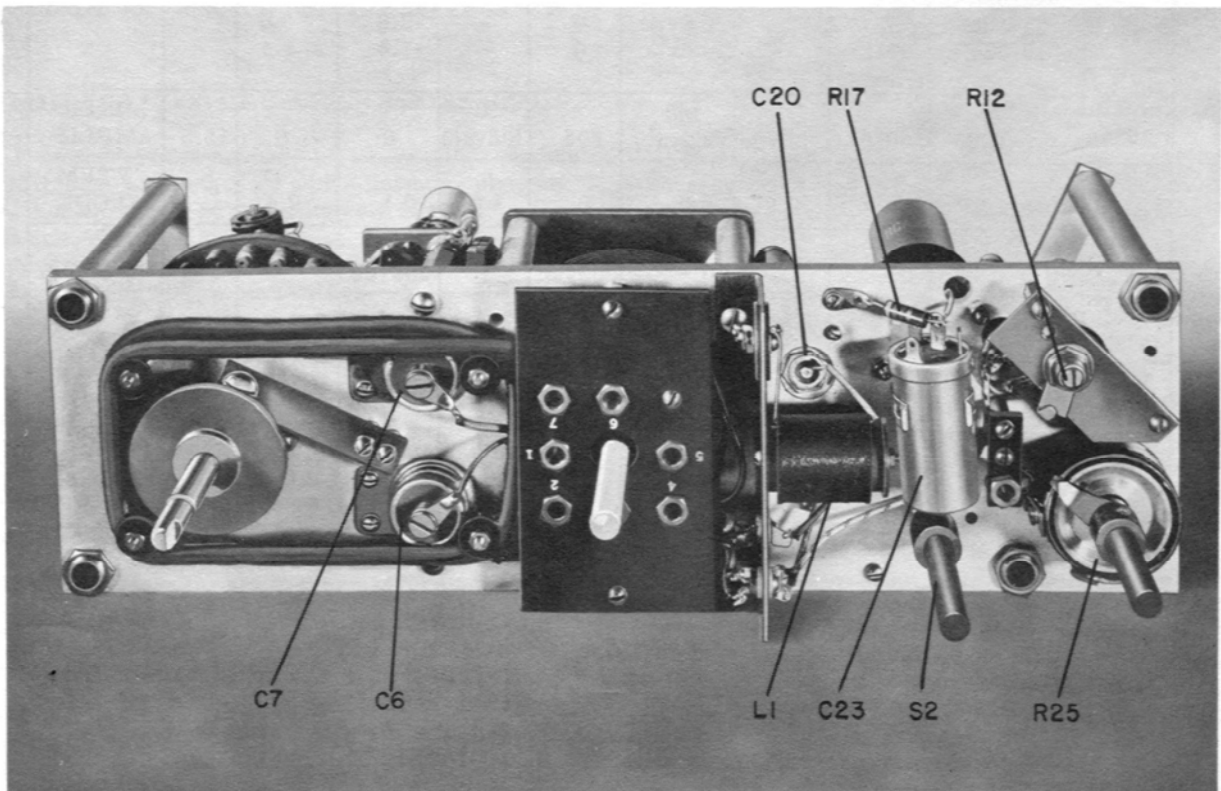

Front View of Oscillator Shelf showing Cable for Servicing.

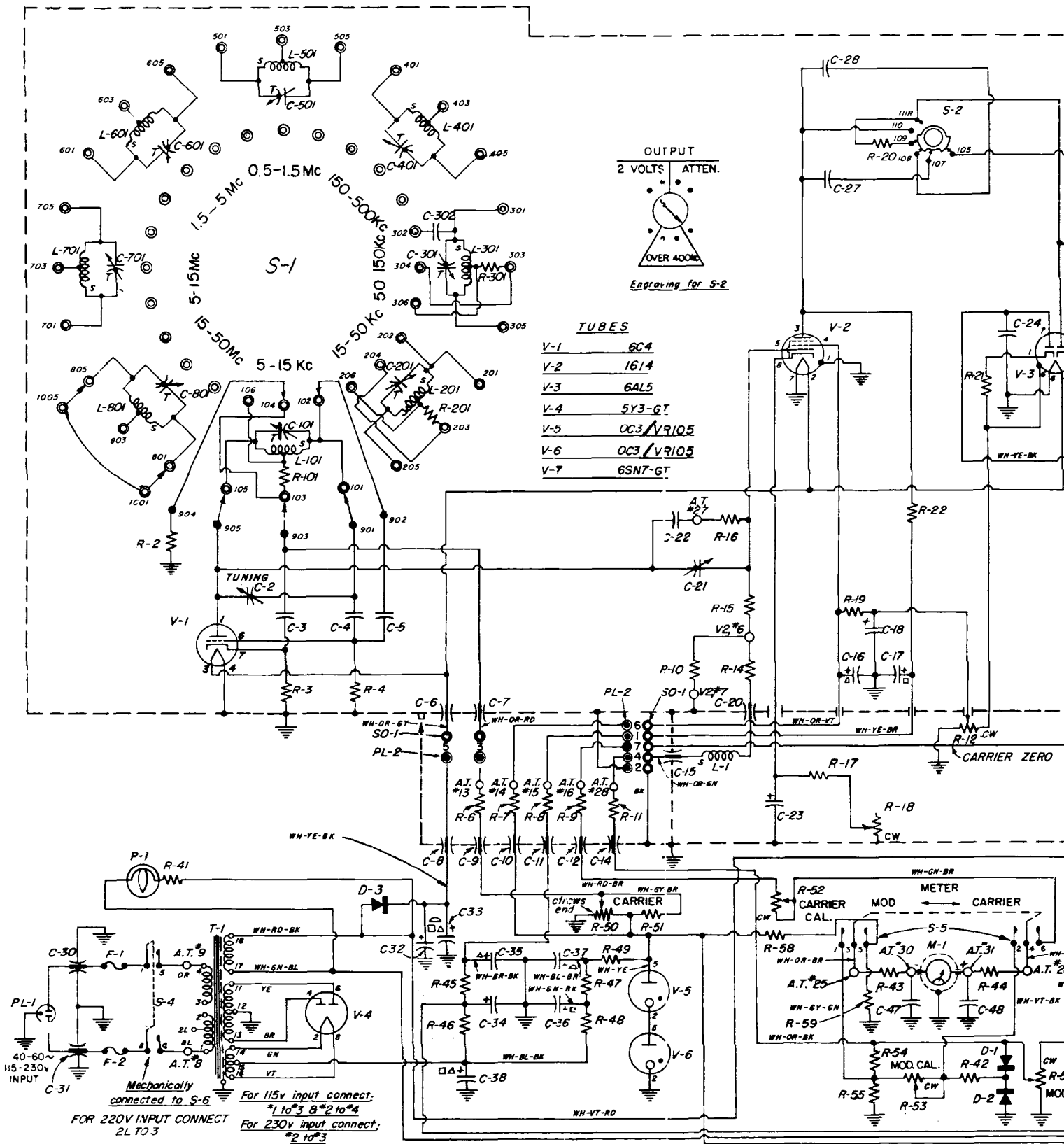

Figure 3. Wiring Diagram

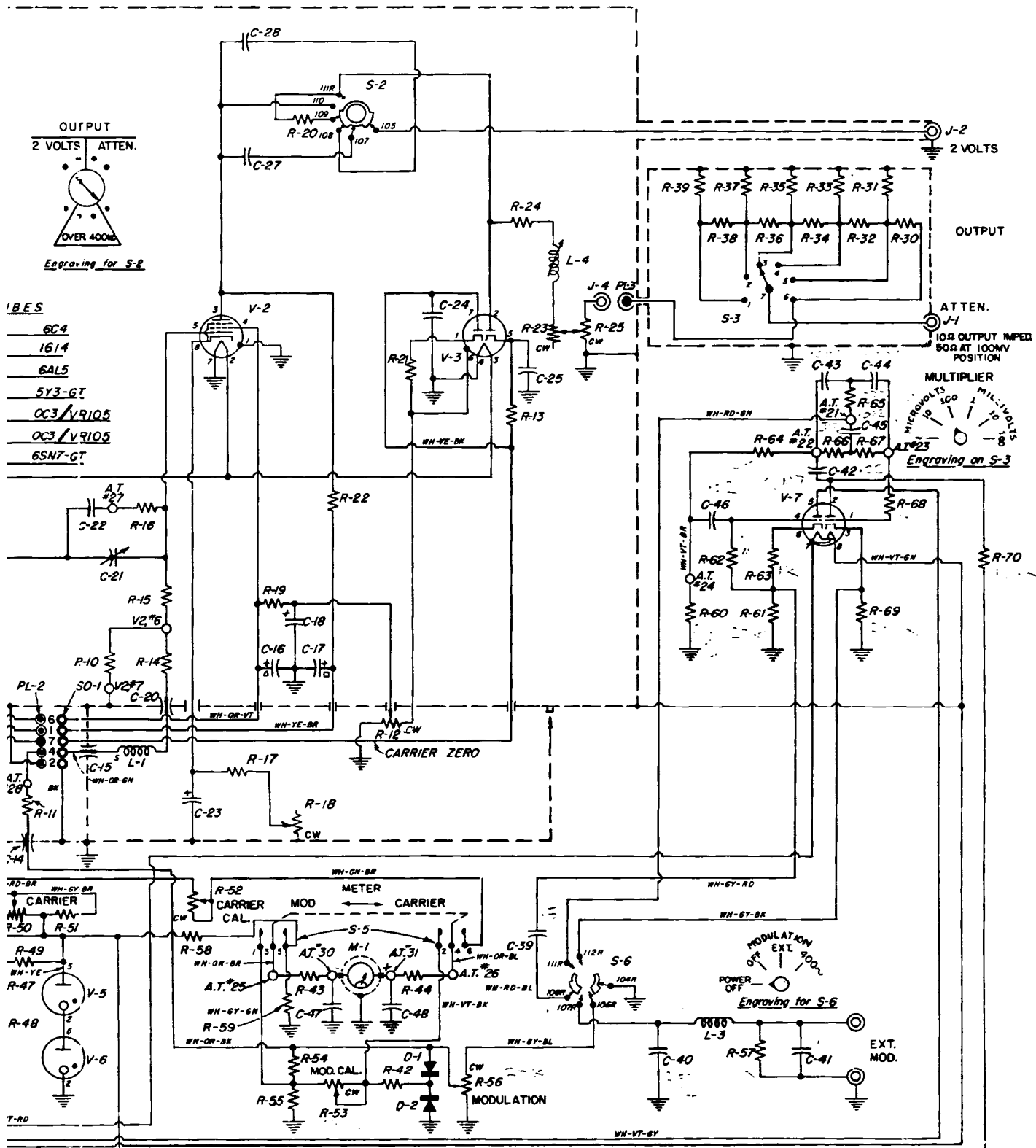

Figure 3. Wiring Diagram for Type 1001-A Standard Signal Generator